

HYPHERPRO

STEERING DAMPER MOUNTING KIT

for

BMW R1200 S '06>

HP2 Sport '08>

MK-BM12-0002 A PART LIST

SD stroke 75	1	Washer M8 ϕ 16	1
Damper Clamp (MP-DB358300)	1	Washer M8 ϕ 21 H4	1
O-Ring	1	-	-
Spacer (MP-SP0001)	2	-	-
Spacer (MP-SP0002)	1	-	-
M8x40 Button head	1	-	-
M8x60 Button head	1	-	-
Lock nut M8	1	-	-

ALL IDEAS, DESIGNS ARRANGEMENTS AND PLANS INDICATED OR REPRESENTED BY THIS DRAWING ARE OWNED BY HYPERPRO AND WERE CREATED, EVOLVED AND DEVELOPED FOR USE ON AND IN CONNECTION WITH THE SPECIFIC PROJECT. NONE SUCH IDEAS, DESIGNS, ARRANGEMENTS OR PLANS SHALL BE USED BY OR DISCLOSED TO ANY PERSON, FIRM OR CORPORATION FOR ANY PURPOSE WHATSOEVER WITHOUT THE WRITTEN PERMISSION OF HYPERPRO.

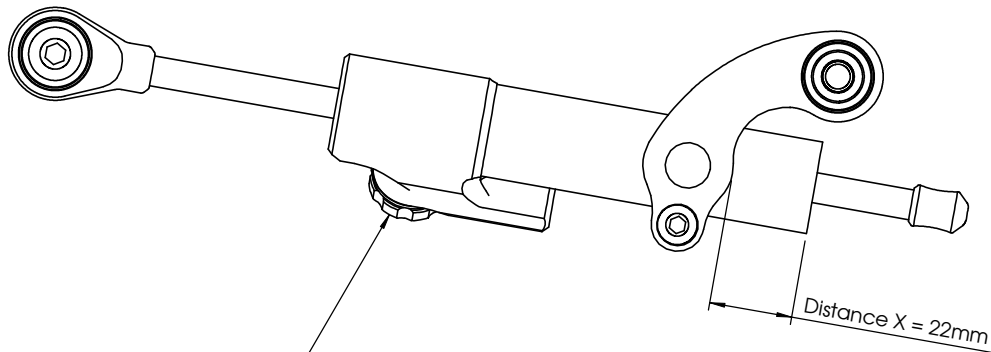

Damping adjustment knob:
 - turn CW to increase damping,
 - turn CCW to decrease damping.

Remove the original steering damper

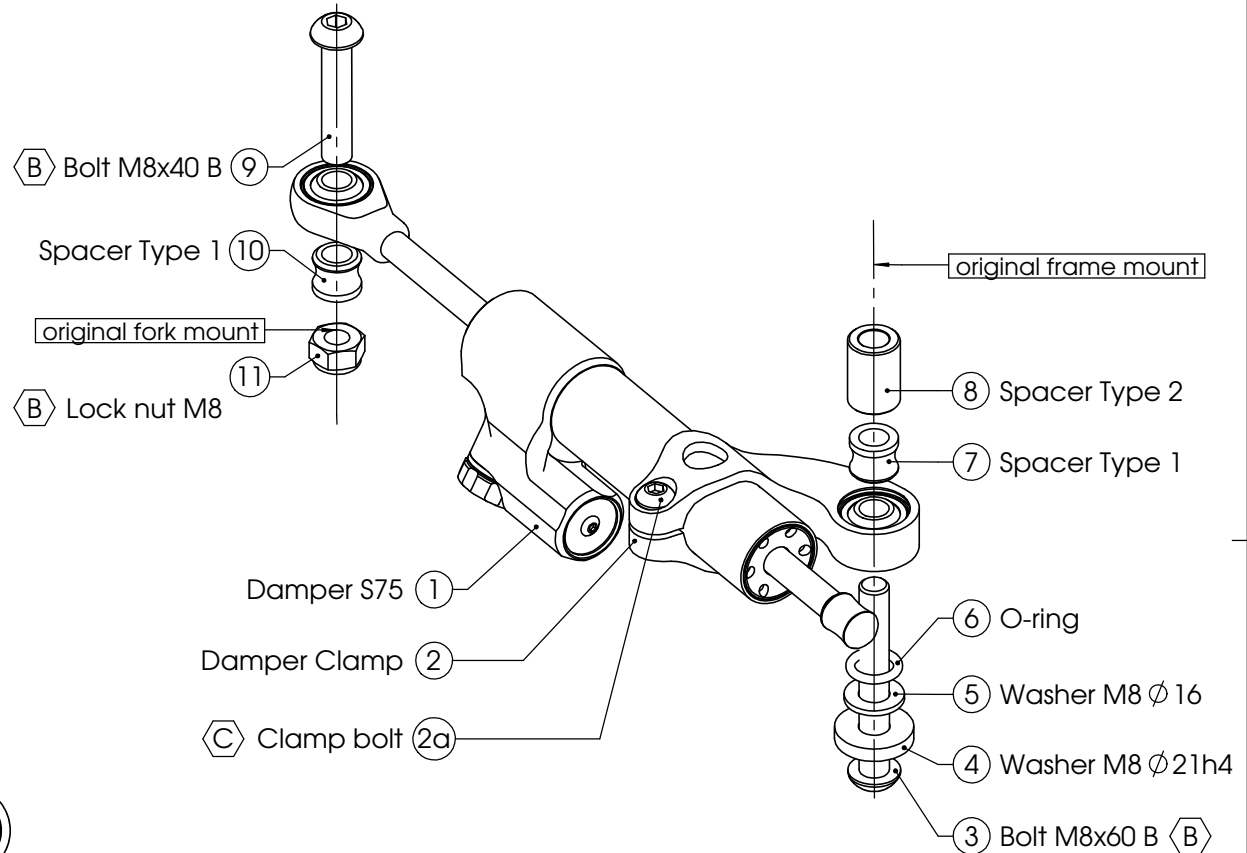

HP2 Sport: relocate the horn wire

* TORQUES	
A: 5-9Nm / 44-80Lbs.In / 4.0-6.4Lbs.Ft	D: 8Nm / 70Lbs.In / 5.9Lbs.Ft
B: 14-17Nm / 124-150Lbs.In / 10.3-12.5Lbs.Ft	E: 55Nm / 486Lbs.In / 40Lbs.Ft
C: 6Nm / 53Lbs.In / 4.4Lbs.Ft	F: Factory torque (see owners manual)

HYPERPRO

STEERING DAMPER MOUNTING KIT

for

BMW R1200 S '06>

HP2 Sport '08>

MK-BM12-0002 A INSTALLATION INSTRUCTIONS

In general:

HYPERPRO can not be held responsible in any way for any form of physical, material, financial or other damage arising from use, assembly or overhaul of HYPERPRO products. HYPERPRO reserves the right to make changes without prior notice.

This product is ONLY TO BE INSTALLED BY A PROFESSIONAL MECHANIC.

This product is only to be used for the motorcycle brand, model and year stated specifically on top of the pages of this manual.

DO NOT attempt to install this product on motorcycles from any different brand, model and/or year than stated on the pages of this manual.

DO NOT use this kit for cars, boats, jet-skies, snowmobiles, ATV's, aircraft, hovercrafts or any other vehicle and/or purpose.

HYPERPRO steering dampers are FOR RACE USE ONLY, NOT FOR HIGHWAY USE!

Before installation:

- Please read the entire manual carefully before starting the installation!
- Check if you have all the tools required. Good tools are a must.
- Protect your bike at the most important places in and around the work area (e.g. tank, fairing, frame, etc.), with a blanket, towel or similar.

During installation:

- Check all operations and parts carefully before, during and after performing each step.
- Clean all surfaces that are required for fitting parts together or for applying self adhesives or loctite, thoroughly with contact cleaner or another degreaser, unless otherwise stated.
- Be careful not to damage or scratch any part of your bike.
- ALWAYS work relaxed and concentrated!! It is very easy to damage something or make a mistake.

After installation:

- Check and make sure that there is no contact between any part of the steering damper kit and any part of the motorcycle. The kit should not hit anything. Steering movement should not be limited by the steering damper. If the steering movement is limited, adjust the position of the tube in the clamp until steering movement is normal again. Do not forget to tighten the clamp bolt again!
- ALWAYS check the steering movement and feeling before each ride !
- FIRST RIDES: Start with the damper turned fully open (turn adjuster knob fully counter clockwise). Start adjusting in between rides with steps of MAX. 2 CLICKS (0.25 TURN) EACH TIME, until the damper is working satisfactory for your riding style.
- NEVER USE MAXIMUM SETTING, ALWAYS OPEN AT LEAST 2 CLICKS (0.25 TURN).
- WARNING ! DAMPER HAS AN ACTIVE / SPEEDSENSITIVE DAMPING SYSTEM;
 - Steering with NORMAL MOVEMENT should be FREE !!
 - Steering with FAST MOVEMENT should be CONTROLLED BY DAMPER !!
- HYPERPRO uses a special seal to reduce friction. The seal uses an oil film to work properly. It is normal that some oil can appear on the pistonrod.
- Damper works with oil: DAMPING CAN BE HARDER AT LOWER TEMPERATURES!

Step 1: Remove the original steering damper

First remove the front mudguard (4x Torx T25 bolts). The HP2 Sport has a 2-piece mudguard that needs to be disassembled before removal (2x Torx T25 bolts).

Next, remove steering damper by removing the M8 nut from the fork and the T40 torx bolt from the lower suspension arm.

Step 2: damper and clamp assembly

Install the tube clamp to the steering damper using:

- S75 steering damper (1)
- Damper clamp (2)

Put the assembly together as shown on page 1: Shove the clamp (2) correctly over the tube of the steering damper until distance X is reached. See pictures for details.

Set the angle of the tube clamp (2) approx. as shown in the picture and tighten the clamp bolt (2a) with a torque of approx. 6Nm/53Lbs.In/4.4Lbs.Ft.

Step 3: installing the steering damper

Install the damper clamp to the frame using:

- Steering damper and tube clamp assembly from step 2
- Bolt M8x60 button head (3)
- Washer M8 ϕ 21 h4 (4)
- Washer M8 ϕ 16 (5)
- O-ring (6)
- Spacer Type 1 (7)
- Spacer Type 2 (8)

Use M8x60 bolt (3), washers (4, 5), O-ring (6) and spacers (7,8) to fit the tube clamp to the original frame mount, on the lower suspension arm. Tighten the M8 bolt with a torque of approx. 14-17Nm/124-150Lbs.In/10.3-12.5Lbs.Ft.

Install the damper ball-joint to the fork using:

- Bolt M8x40 button head (9)
- Spacer Type 1 (10)
- Lock nut M8 (11)

Use the M8x40 bolt (9), spacer (10) and lock nut (11) to fit the ball-joint to the original fork mount. Tighten the M8 bolt and nut with a torque of approx. 14-17Nm/124-150Lbs.In/10.3-12.5Lbs.Ft.

Check if the damper does not touch anything (e.g. engine, fork) when steering from left to right. Check if the bike can make it's full steering angle from left to right.

Adjust the position of the damper if necessary by loosening and retightening the clamp bolt (2a).

HP2 Sport: re-locate the horn wire

Remove the zip-ties that hold the horn wire to the horn bracket. Re-locate the wire with new zip-ties in a way that it can not interfere with the steering damper.