

HYPERPRO

LOWERING KIT / VERLAGINGSSET

for

YAMAHA YZF 600 R6 Models '06>

LK-YA06-011-40 PART LIST

PR121690 - Pull rod / trekstang	2
SL144711 - Stroke limiter/ slagbeperker	1
Washers / ringen M12	2
-	-

ALL IDEAS, DESIGNS, ARRANGEMENTS AND PLANS INDICATED OR REPRESENTED BY THIS DRAWING ARE OWNED BY HYPERPRO AND WERE CREATED, EVOLVED AND DEVELOPED FOR USE ON AND IN CONNECTION WITH THE SPECIFIC PROJECT. NONE SUCH IDEAS, DESIGNS, ARRANGEMENTS OR PLANS SHALL BE USED BY OR DISCLOSED TO ANY PERSON, FIRM OR CORPORATION FOR ANY PURPOSE WHATSOEVER WITHOUT THE WRITTEN PERMISSION OF HYPERPRO.

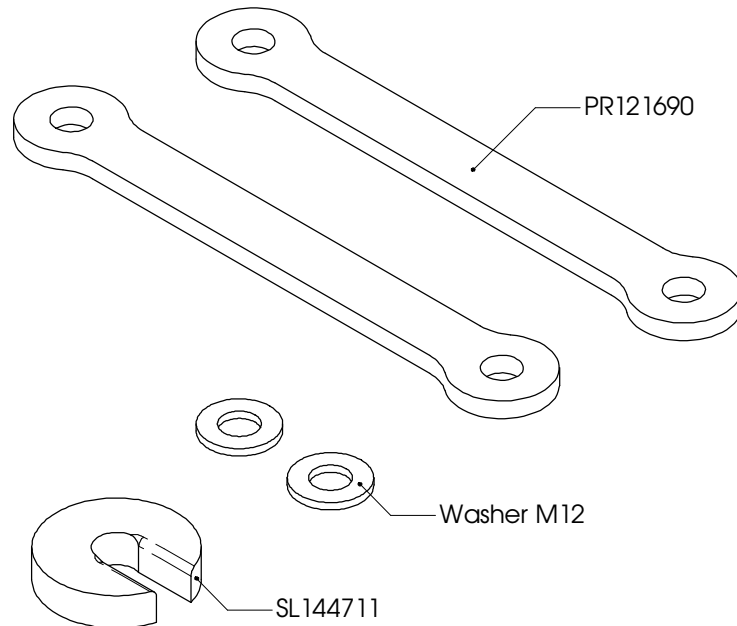

Inbouw handleiding

VOORZIJD

De vorkpoten maximaal 20 mm door de bovenste kroonplaat heen steken. De veer-voorspanning minimaal zetten (tegen de klok in draaien). Luchtkamer reduceren als de vork wil doorslaan.

ACHTERZIJD

De bestaande trekstangen vervangen door de HYPERPRO trekstangen. Gebruik de ringen om het verschil in materiaaldikte uit te vullen. De slagbeperker boven op het aanslagrubber van de achterschokbreker plaatsen. Het achterwiel eerst belasten voordat alles vastgezet wordt.

LET OP! DE LENGTE VAN DE ZIJSTANDAARD MOET 25-30mm INGEKORT WORDEN.

Instruction manual

FRONT

Mount the fork legs max 20mm through the triple clamp. Turn the preload adjuster to minimum preload (counter clockwise). Reduce the air chamber if the fork hits the end of its stroke.

REAR

Replace the original link by the HYPERPRO lowering link. Use the washers to compensate the difference in material thickness. Put the stroke limiter on top of the bump rubber of the rear shock. Put some pressure on the rear wheel before fully tightening all the bolts.

WARNING! SHORTEN THE SIDE-STAND 25-30mm.

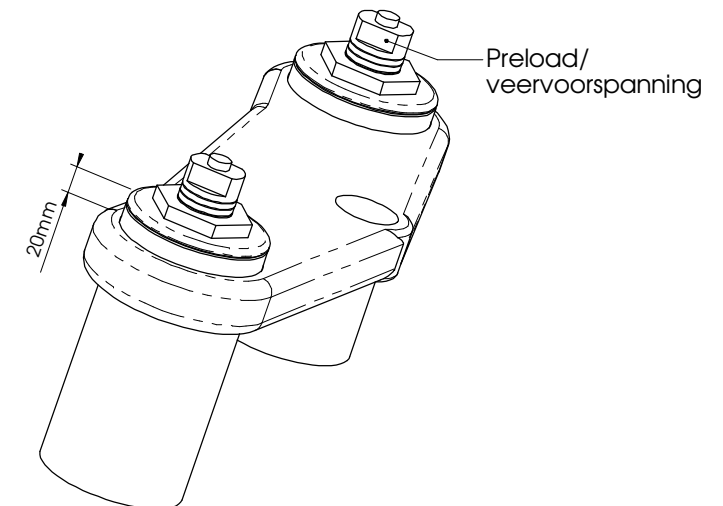

See WWW.HYPERPRO.COM for more info about our products.