

# HYPERPRO

## LOWERING KIT / VERLAGINGSSET

for

### TRIUMPH DAYTONA 675

Models '06> (D67LC)

#### LK-TR06-004-35 PART LIST

LINK0026 - Lowering link/ verlagingslink	2
-	-
-	-
-	-

ALL IDEAS, DESIGNS, ARRANGEMENTS AND PLANS INDICATED OR REPRESENTED BY THIS DRAWING ARE OWNED BY HYPERPRO AND WERE CREATED, EVOLVED AND DEVELOPED FOR USE ON AND IN CONNECTION WITH THE SPECIFIC PROJECT. NONE SUCH IDEAS, DESIGNS, ARRANGEMENTS OR PLANS SHALL BE USED BY OR DISCLOSED TO ANY PERSON, FIRM OR CORPORATION FOR ANY PURPOSE WHATSOEVER WITHOUT THE WRITTEN PERMISSION OF HYPERPRO.

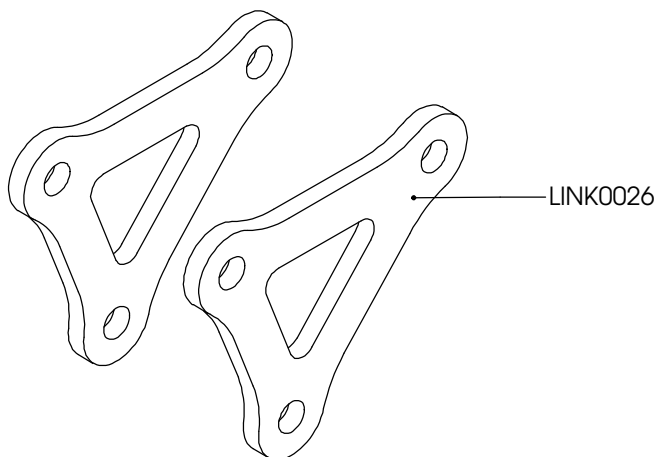

## Inbouw handleiding

### VOORZIJDJE

De vorkpoten maximaal 11 mm door de bovenste kroonplaat heen steken. De veer-voorspanning minimaal zetten (tegen de klok in draaien).

### ACHTERZIJDJE

De bestaande links vervangen door de HYPERPRO verlagingslinks. Let er hierbij op dat de pijl boven in de rijrichting wijst. Het achterwiel eerst belasten voordat de link vastgezet word.

LET OP! DE LENGTE VAN DE ZIJSTANDAARD MOET  $\pm 20$ mm INGEKORT WORDEN. AFTERMARKET SPATBORDEN KUNNEN NIET TOEGEPAST WORDEN.

## Instruction manual

### FRONT

Mount the fork legs max 11mm through the triple clamp. Turn the preload adjuster to minimum preload (counter clockwise).

### REAR

Replace the original link by the HYPERPRO lowering link. Make sure the arrow above is pointing in the riding direction. Put some pressure on the rear wheel before tightening the link.

WARNING! SHORTEN THE SIDE-STAND  $\pm 20$ mm. AFTERMARKET REAR MUDGUARDS CAN NO LONGER BE USED.

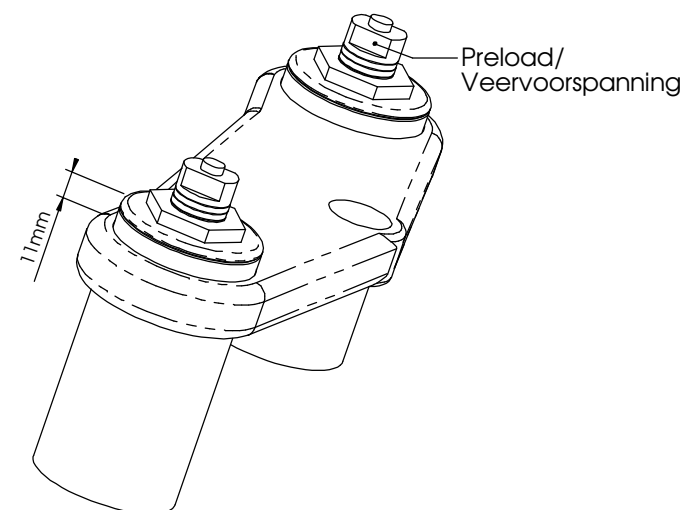

See [WWW.HYPERPRO.COM](http://WWW.HYPERPRO.COM) for more info about our products.