

# HYPERPRO

## LOWERING KIT / VERLAGINGSSET

for

## SUZUKI DL 650 V-STROM

Models '04>

### LK-SU06-013-30 PART LIST

PR121510 - Pull rod/ trekstang	2
SL254711 - Strokelimiter/ slagbeperker	1
-	-
-	-

ALL IDEAS, DESIGNS, ARRANGEMENTS AND PLANS INDICATED OR REPRESENTED BY THIS DRAWING ARE OWNED BY HYPERPRO AND WERE CREATED, EVOLVED AND DEVELOPED FOR USE ON AND IN CONNECTION WITH THE SPECIFIC PROJECT. NONE SUCH IDEAS, DESIGNS, ARRANGEMENTS OR PLANS SHALL BE USED BY OR DISCLOSED TO ANY PERSON, FIRM OR CORPORATION FOR ANY PURPOSE WHATSOEVER WITHOUT THE WRITTEN PERMISSION OF HYPERPRO.

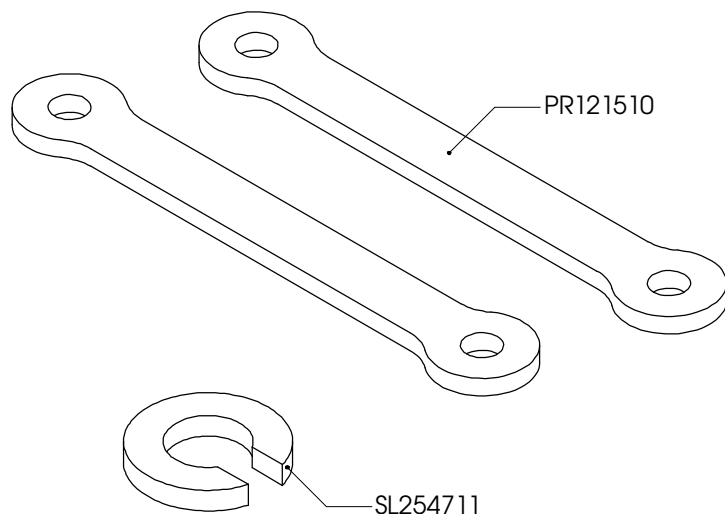

### Inbouw handleiding

#### VOORZIJDE

De vorkpoten maximaal 20mm door de bovenste kroonplaat heen steken.

#### ACHTERZIJDE

De bestaande trekstangen vervangen door de HYPERPRO trekstangen.  
De slagbeperker onder het aanslagrubber van de achterschokbreker plaatsen.  
Het achterwiel eerst belasten voordat de link vastgezet wordt.

LET OP! DE LENGTE VAN DE ZIJSTANDAARD MOET 15-20mm INGEKORT WORDEN.

### Instruction manual

#### FRONT

Mount the fork legs max 20 mm through the triple clamp.

#### REAR

Replace the original pull rods by the HYPERPRO lowering pull rods.  
Put the strokelimiter under the bump rubber of the shock.  
Put some pressure on the rear wheel before tightening the link.

WARNING! SHORTEN THE SIDE-STAND 15-20mm.

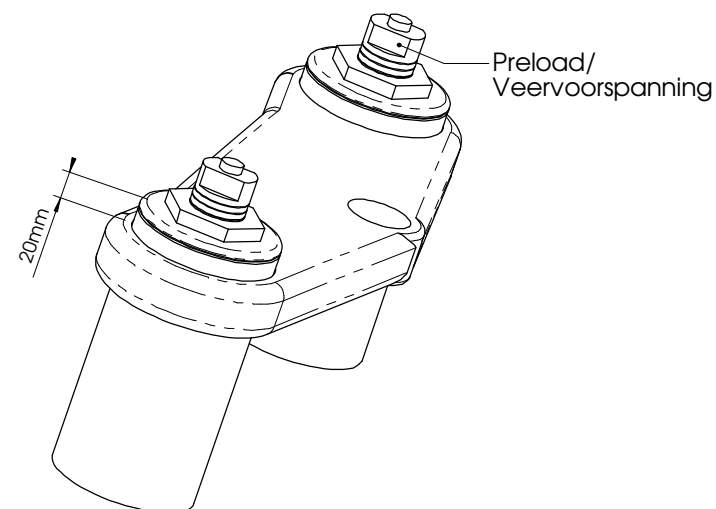

See [WWW.HYPERPRO.COM](http://WWW.HYPERPRO.COM) for more info about our products.