

HYPERPRO

LOWERING KIT / VERLAGINGSSET for KAWASAKI ZX 12 R Models '00-'01

LK-KA12-001-35 PART LIST

Link 70	2
Strokelimiter/Slagbeperker	1
-	-
-	-

ALL IDEAS, DESIGNS, ARRANGEMENTS AND PLANS INDICATED OR REPRESENTED BY THIS DRAWING ARE OWNED BY HYPERPRO AND WERE CREATED, EVOLVED AND DEVELOPED FOR USE ON AND IN CONNECTION WITH THE SPECIFIC PROJECT. NONE SUCH IDEAS, DESIGNS, ARRANGEMENTS OR PLANS SHALL BE USED BY OR DISCLOSED TO ANY PERSON, FIRM OR CORPORATION FOR ANY PURPOSE WHATSOEVER WITHOUT THE WRITTEN PERMISSION OF HYPERPRO.

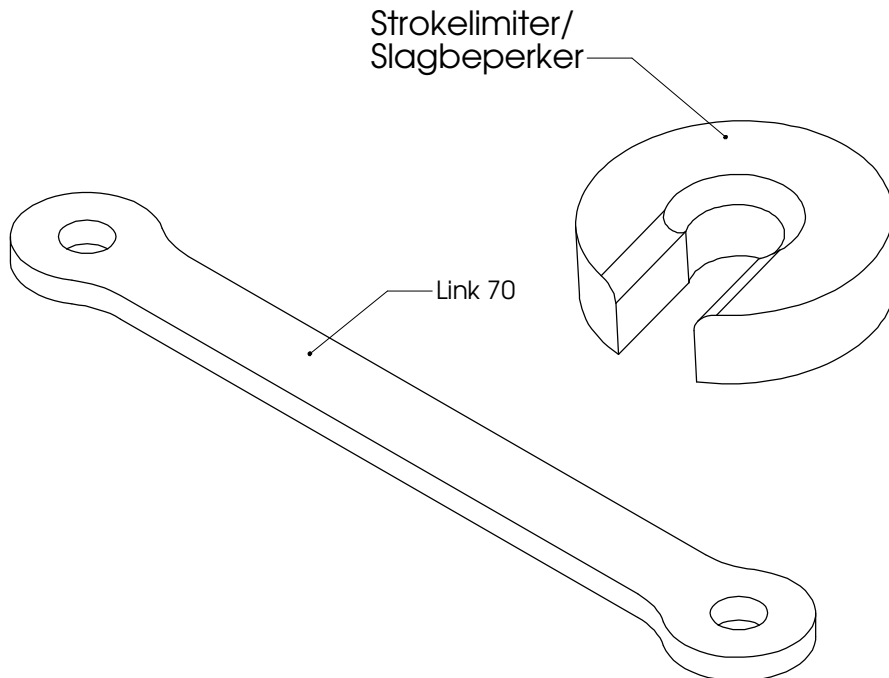

Inbouw handleiding

Meet de lengte van de originele link. Van hart tot hart moet deze 181 mm zijn, bij 187 mm is een andere set benodigd (LK-KA12-002-30)

VOORZIJDJE

De vorkpoten maximaal 3 mm door de bovenste kroonplaat heen steken. De veervoorspanning minimaal zetten (tegen de klok in draaien). De luchtkamer reduceren als de vork wil doorslaan.

ACHTERZIJDJE

De bestaande link vervangen door de HYPERPRO verlagingslink. Plaats de slagbeperker over het aanslagrubber op de schokbreker, met de ronde kant naar het rubber toe. Het achterwiel eerst belasten voordat de link vastgezet word.

LET OP! DE LENGTE VAN DE ZIJSTANDAARD MOET 20-25mm INGEKORT WORDEN. AFTERMARKET SPATBORDEN KUNNEN NIET TOEGEPAST WORDEN.

Instruction manual

Measure the length of the original link. From centre to centre this should be 181 mm, if it's 187 mm an other kit is used (LK-KA12-002-30)

FRONT

Mount the fork legs max 3 mm through the triple clamp. Turn the preload adjuster to minimum preload (ounter clockwise). Reduce the air chamber if the fork hits the end of its stroke.

REAR

Replace the original link by the HYPERPRO lowering link. Place the strokelimter over the bumprubber on the shock, with the round side facing the rubber. Put some pressure on the rear wheel before tightening the link.

WARNING! SHORTEN THE SIDE-STAND 20-25mm. AFTERMARKET REAR MUDGUARDS CAN NO LONGER BE USED.

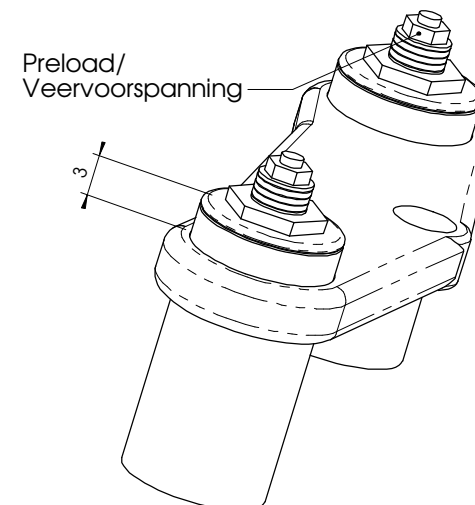

See WWW.HYPERPRO.COM for more info about our products.