

# HYPERPRO

## LOWERING KIT / VERLAGINGSSET

for

### KAWASAKI ZX-10R NINJA Models '04>

#### LK-KA10-001-30 PART LIST

PR121940 - Pull rods/ trekstangen	2
-	-
-	-
-	-

ALL IDEAS, DESIGNS, ARRANGEMENTS AND PLANS INDICATED OR REPRESENTED BY THIS DRAWING ARE OWNED BY HYPERPRO AND WERE CREATED, EVOLVED AND DEVELOPED FOR USE ON AND IN CONNECTION WITH THE SPECIFIC PROJECT. NONE SUCH IDEAS, DESIGNS, ARRANGEMENTS OR PLANS SHALL BE USED BY OR DISCLOSED TO ANY PERSON, FIRM OR CORPORATION FOR ANY PURPOSE WHATSOEVER WITHOUT THE WRITTEN PERMISSION OF HYPERPRO.

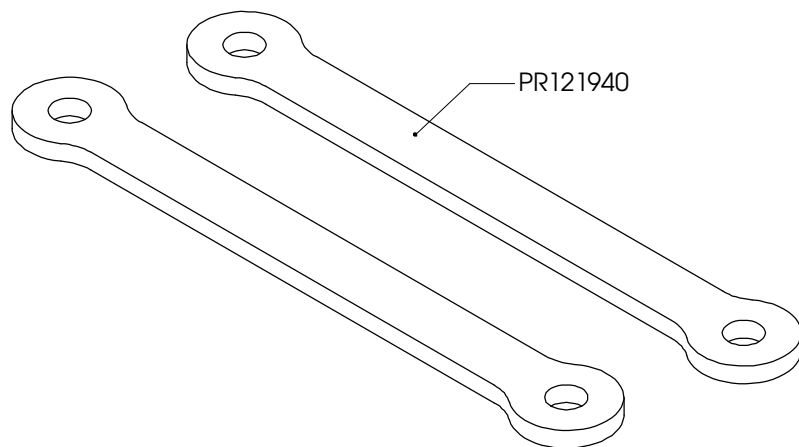

### Inbouw handleiding

#### VOORZIJD

De vorkpoten maximaal 8mm door de bovenste kroonplaat heen steken. De veer-voorspanning minimaal zetten (tegen de klok in draaien). De luchtkamer reduceren als de vork will doorslaan.

#### ACHTERZIJD

De bestaande link vervangen door de HYPERPRO verlagingslink. Het achterwiel eerst belasten voordat de link vastgezet word.

LET OP! DE LENGTE VAN DE ZIJSTANDAARD MOET 15-20mm INGEKORT WORDEN.

### Instruction manual

#### FRONT

Mount the fork legs max 8mm through the triple clamp. Turn the preload adjuster to minimum preload (counter clockwise). Reduce the air chamber in the fork if the fork hits the end of its stroke.

#### REAR

Replace the original link by the HYPERPRO lowering link. Put some pressure on the rear wheel before tightening the link.

WARNING! SHORTEN THE SIDE-STAND 15-20mm.

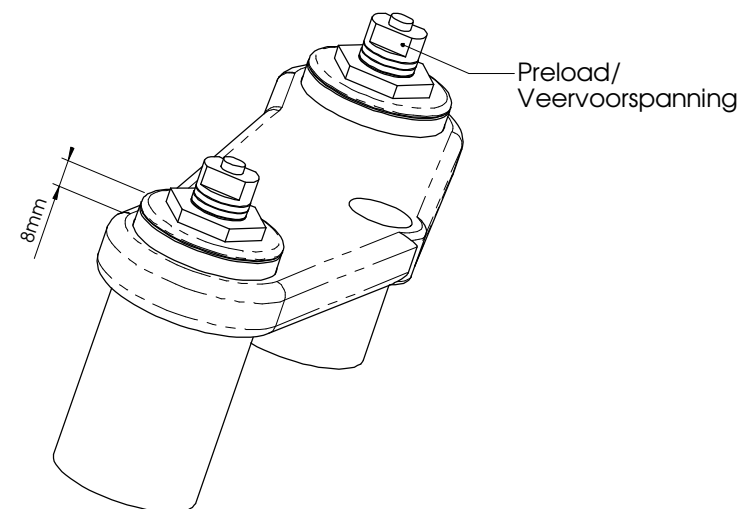

See [WWW.HYPERPRO.COM](http://WWW.HYPERPRO.COM) for more info about our products.