

HYPERPRO

LOWERING KIT / VERLAGINGSSET

for

KAWASAKI Z 750 Models '04>

LK-KA07-002-50 PART LIST

PR121980 - Pull rod/ trekstang	2
SL144710 - Stroke limiter / slagbepערker	2
-	-
-	-

ALL IDEAS, DESIGNS, ARRANGEMENTS AND PLANS INDICATED OR REPRESENTED BY THIS DRAWING ARE OWNED BY HYPERPRO AND WERE CREATED, EVOLVED AND DEVELOPED FOR USE ON AND IN CONNECTION WITH THE SPECIFIC PROJECT. NONE SUCH IDEAS, DESIGNS, ARRANGEMENTS OR PLANS SHALL BE USED BY OR DISCLOSED TO ANY PERSON, FIRM OR CORPORATION FOR ANY PURPOSE WHATSOEVER WITHOUT THE WRITTEN PERMISSION OF HYPERPRO.

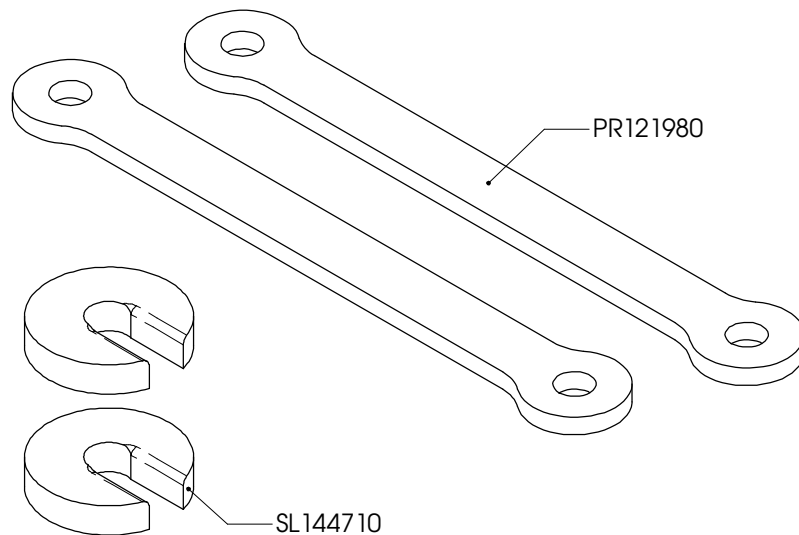

Inbouw handleiding

VOORZIJDE

De vorkpoten maximaal 10 mm door de bovenste kroonplaat heen steken.
Voorspanbussen 20 mm inkorten.
Luchtkamer naar 80mm brengen (gemeten met de vorkpoten ingedrukt, zonder veer).

ACHTERZIJDE

De bestaande trekstangen vervangen door de HYPERPRO trekstangen. Het achterwiel eerst belasten voordat de link vastgezet wordt. Plaats slagbepערkers boven het aanslagrubber van de schokdemper.

LET OP! DE LENGTE VAN DE ZIJSTANDAARD MOET 35-40mm INGEKORT WORDEN.
AFTERMARKET ACHTERSPEATBORDEN KUNNEN NIET MEER WORDEN TOEGEPAST.

Instruction manual

FRONT

Mount the fork legs max 10mm through the triple clamp. Shorten the spacers with 20mm.
Reduce the air chamber to 80mm (measured with the forklegs compressed, without spring).

REAR

Replace the original pull rods with the HYPERPRO lowering pull rods. Put some pressure on the rear wheel before tightening the link. Put the stroke limiters on top of the bump rubber of the rear shock.

WARNING! SHORTEN THE SIDE-STAND 35-40mm.
AFTERMARKET REAR MUDGUARDS CAN NO LONGER BEEN USED.

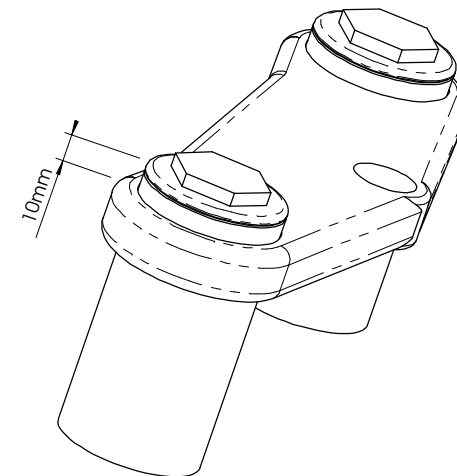

See WWW.HYPERPRO.COM for more info about our products.