

HYPERPRO

LOWERING KIT / VERLAGINGSSET

for

KAWASAKI ZX6-R NINJA Models '00-'02

LK-KA06-003-35 PART LIST

PR121920 - Pull rods/ trekstangen	2
-	-
-	-
-	-

ALL IDEAS, DESIGNS, ARRANGEMENTS AND PLANS INDICATED OR REPRESENTED BY THIS DRAWING ARE OWNED BY HYPERPRO AND WERE CREATED, EVOLVED AND DEVELOPED FOR USE ON AND IN CONNECTION WITH THE SPECIFIC PROJECT. NONE SUCH IDEAS, DESIGNS, ARRANGEMENTS OR PLANS SHALL BE USED BY OR DISCLOSED TO ANY PERSON, FIRM OR CORPORATION FOR ANY PURPOSE WHATSOEVER WITHOUT THE WRITTEN PERMISSION OF HYPERPRO.

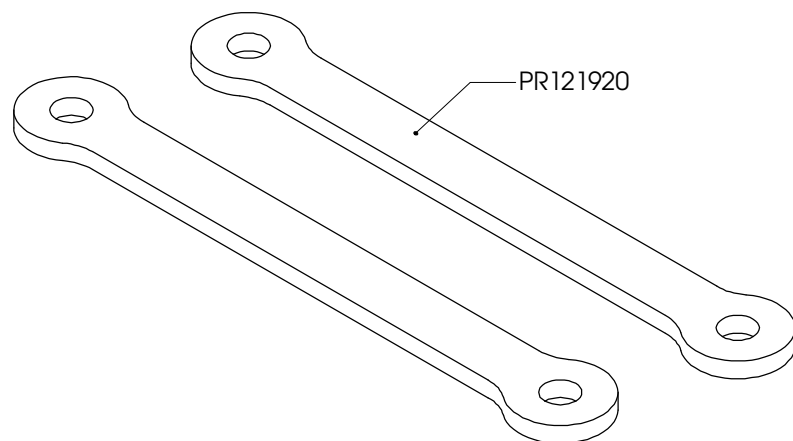

Inbouw handleiding

VOORZIJDJE

De vorkpoten maximaal 10 mm door de bovenste kroonplaat heen steken. De veer-voorspanning minimaal zetten (tegen de klok in draaien).

ACHTERZIJDJE

De bestaande link vervangen door de HYPERPRO verlagingslink. Het achterwiel eerst belasten voordat de link vastgezet wordt.

LET OP! DE LENGTE VAN DE ZIJSTANDAARD MOET 20-25mm INGEKORT WORDEN.

Instruction manual

FRONT

Mount the fork legs max 10mm through the triple clamp. Turn the preload adjuster to minimum preload (counter clockwise).

REAR

Replace the original link by the HYPERPRO lowering link. Put some pressure on the rear wheel before tightening the link.

WARNING! SHORTEN THE SIDE-STAND 20-25mm.

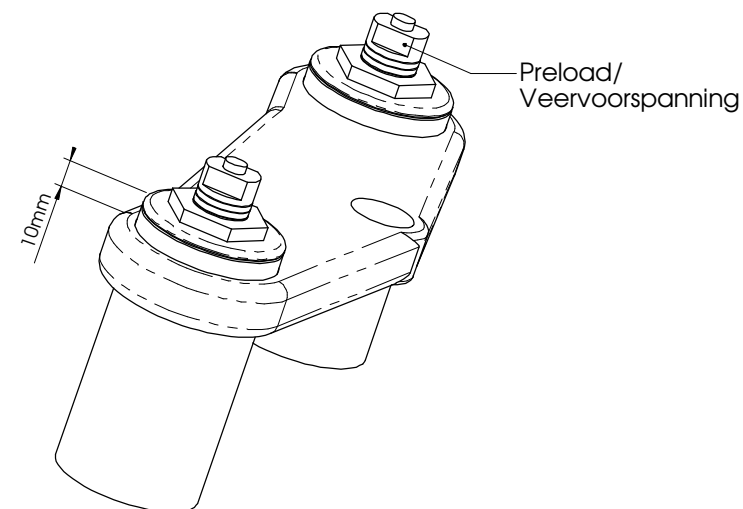

See WWW.HYPERPRO.COM for more info about our products.