

HYPERPRO

LOWERING KIT / VERLAGINGSSET

for

KAWASAKI KLE 500 Models '91>

LK-KA05-002-60 PART LIST

PR151530 - Lowering link/ verlagingslink	2
SL143520 - Stroke limiter/ slagbeperker	1
-	-
-	-

ALL IDEAS, DESIGNS, ARRANGEMENTS AND PLANS INDICATED OR REPRESENTED BY THIS DRAWING ARE OWNED BY HYPERPRO AND WERE CREATED, EVOLVED AND DEVELOPED FOR USE ON AND IN CONNECTION WITH THE SPECIFIC PROJECT. NONE SUCH IDEAS, DESIGNS, ARRANGEMENTS OR PLANS SHALL BE USED BY OR DISCLOSED TO ANY PERSON, FIRM OR CORPORATION FOR ANY PURPOSE WHATSOEVER WITHOUT THE WRITTEN PERMISSION OF HYPERPRO.

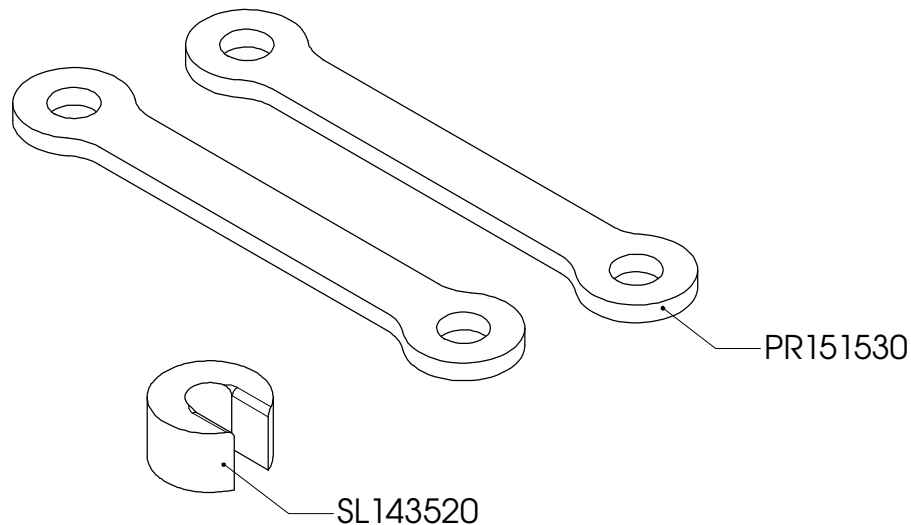

Inbouw handleiding

VOORZIJD

De voorspanbussen met 30mm inkorten.
De ring tussen de voorspanbus en de veer verwijderen.
De luchtkamer naar 130mm brengen (gemeten met de vorkpoten ingedrukt zonder veer).

ACHTERZIJD

Verwijder de shock. De bestaande link vervangen door de HYPERPRO verlagingslink.
verwijder de veer. Halveer het bumprubber en plaats de slagbeperker boven het bump
rubber. Monteer de veer. Monteer de shock.
Het achterwiel eerst belasten voordat de link vastgezet wordt.

LET OP! DE LENGTE VAN DE ZIJSTANDAARD MOET 40-45mm INGEKORT WORDEN.
AFTERMARKET SPATBORDEN KUNNEN NIET TOEGEPAST WORDEN.

Instruction manual

FRONT

Shorten the preload bushes with 30mm.
Remove the washer between the preload bush and the spring.
Reduce the air chamber to 130mm (measured with the forklegs compressed, without spring).

REAR

Remove the shock. Replace the original link by the HYPERPRO lowering link.
Remove the spring. Halve the bumprubber and place the strokelimiter over the
bumprubber on the shock. Mount the spring. Mount the shock.
Put some pressure on the rear wheel before tightening the link.

WARNING! SHORTEN THE SIDE-STAND 40-45mm.
AFTERMARKET REAR MUDGUARDS CAN NO LONGER BE USED.

See WWW.HYPERPRO.COM for more info about our products.