

# HYPERPRO

## LOWERING KIT / VERLAGINGSSET for HONDA CBR 900 RR Models '98-'99

### LK-HO09-003-35 PART LIST

LINK0068 - Lowering link/ verlagingslink	2
SL144407 - Strokelimiter/ slagbepker	1
-	-
-	-

ALL IDEAS, DESIGNS, ARRANGEMENTS AND PLANS INDICATED OR REPRESENTED BY THIS DRAWING ARE OWNED BY HYPERPRO AND WERE CREATED, EVOLVED AND DEVELOPED FOR USE ON AND IN CONNECTION WITH THE SPECIFIC PROJECT. NONE SUCH IDEAS, DESIGNS, ARRANGEMENTS OR PLANS SHALL BE USED BY OR DISCLOSED TO ANY PERSON, FIRM OR CORPORATION FOR ANY PURPOSE WHATSOEVER WITHOUT THE WRITTEN PERMISSION OF HYPERPRO.

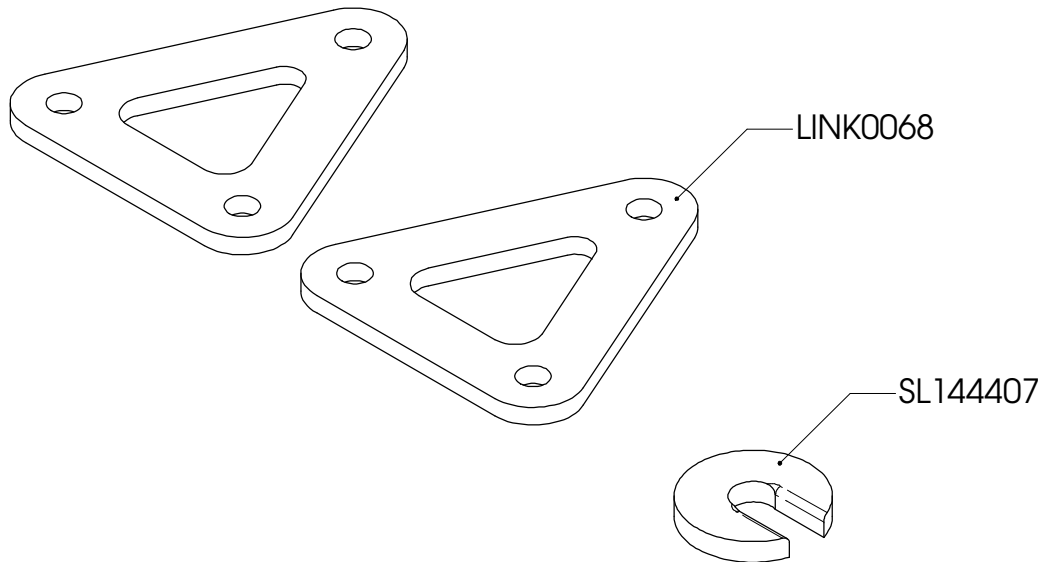

See [WWW.HYPERPRO.COM](http://WWW.HYPERPRO.COM) for more info about our products.

### Inbouw handleiding

CBR 900 RR met typenummer SC33 TMO of SC33 VM1 hebben een andere set nodig.

#### VOORZIJDE

De vorkpoten maximaal 10 mm door de bovenste kroonplaat heen steken. De veer-voorspanning minimaal zetten (tegen de klok in draaien). De luchtkamer reduceren als de vork wil doorslaan.

#### ACHTERZIJDE

De bestaande link vervangen door de HYPERPRO verlagingslink, met de pijl in de rijrichting. De slagbepker over het aanslagrubber op de schokbreker plaatsen. Het achterwiel eerst belasten voordat de link vastgezet wordt.

LET OP! DE LENGTE VAN DE ZIJSTANDAARD MOET 20-25mm INGEKORT WORDEN. AFTERMARKET ACHTERSPEATBORDEN KUNNEN NIET MEER WORDEN TOEGEPAST.

### Instruction manual

CBR 900 RR with typenumber SC33 TMO or SC33 VM1 need a different kit.

#### FRONT

Mount the fork legs max 10mm through the triple clamp. Turn the preload adjuster to minimum preload (counter clockwise). Reduce the air chamber if the fork hits the end of its stroke.

#### REAR

Replace the original link by the HYPERPRO lowering link, with the arrow in the driving direction. Place the strokelimiter over the bumprubber on the shock. Put some pressure on the rear wheel before tightening the link.

WARNING! SHORTEN THE SIDE-STAND 20-25mm. AFTERMARKET REAR MUDGUARDS CAN NO LONGER BE USED.

