

HYPERPRO

LOWERING KIT / VERLAGINGSSET

for

HONDA CBR 900 RR Models '96-'97

LK-H009-002-35 PART LIST

LINK0021 - Lowering link/ verlagingslink	2
SL244710 - Stroke limiter/ slagbeperker	1
-	-
-	-

ALL IDEAS, DESIGNS, ARRANGEMENTS AND PLANS INDICATED OR REPRESENTED BY THIS DRAWING ARE OWNED BY HYPERPRO AND WERE CREATED, EVOLVED AND DEVELOPED FOR USE ON AND IN CONNECTION WITH THE SPECIFIC PROJECT. NONE SUCH IDEAS, DESIGNS, ARRANGEMENTS OR PLANS SHALL BE USED BY OR DISCLOSED TO ANY PERSON, FIRM OR CORPORATION FOR ANY PURPOSE WHATSOEVER WITHOUT THE WRITTEN PERMISSION OF HYPERPRO.

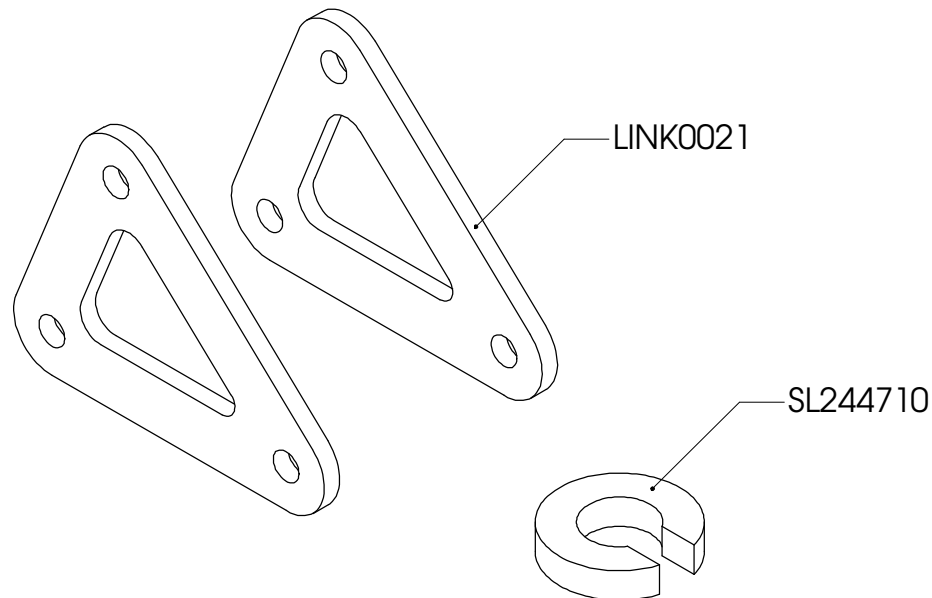

Inbouw handleiding

VOORZIJDJE

De vorkpoten maximaal 10 mm door de bovenste kroonplaat heen steken. De veer-voorspanning minimaal zetten (tegen de klok in draaien). De luchtkamer reduceren als de vork wil doorslaan.

ACHTERZIJDJE

De bestaande link vervangen door de HYPERPRO verlagingslink. Let er hierbij op dat de pijl in de rijrichting wijst. De witte ring als slagbeperker onder het aanslagrubber van de achterschokbreker plaatsen. Het achterwiel eerst belasten voordat de link vastgezet word.

LET OP! DE LENGTE VAN DE ZIJSTANDAARD MOET 20-25mm INGEKORT WORDEN.

Instruction manual

FRONT

Mount the fork legs max 10mm through the triple clamp. Turn the preload adjuster to minimum preload (counter clockwise). Reduce the air chamber if the fork hits the end of its stroke.

REAR

Replace the original link by the HYPERPRO lowering link. Make sure that the arrows are pointing in riding direction.
Put the strokelimiter under the bump rubber of the rear shock
Put some pressure on the rear wheel before tightening the link.

WARNING! SHORTEN THE SIDE-STAND 20-25mm.

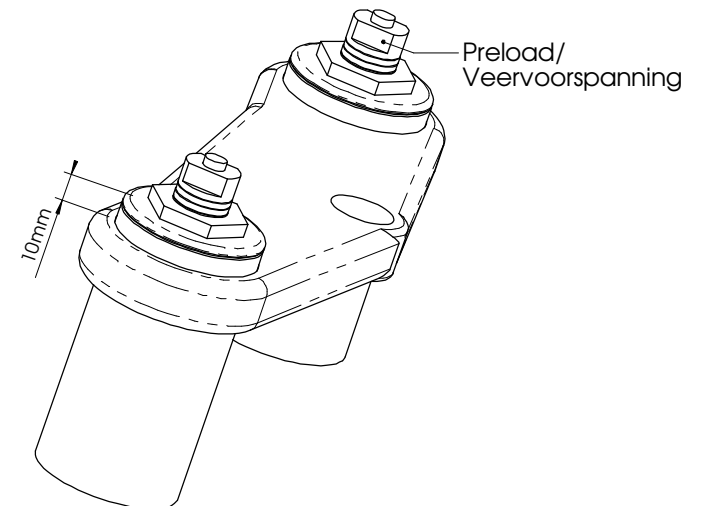

See WWW.HYPERPRO.COM for more info about our products.