

# HYPERPRO

## LOWERING KIT / VERLAGINGSSET

for

### HONDA CBR 600 RR (PC 40)

### Models '07>

#### LK-H006-009-40 PART LIST

LINK0017 - Lowering link/ verlagingslink	2
-	-
-	-
-	-

ALL IDEAS, DESIGNS, ARRANGEMENTS AND PLANS INDICATED OR REPRESENTED BY THIS DRAWING ARE OWNED BY HYPERPRO AND WERE CREATED, EVOLVED AND DEVELOPED FOR USE ON AND IN CONNECTION WITH THE SPECIFIC PROJECT. NONE SUCH IDEAS, DESIGNS, ARRANGEMENTS OR PLANS SHALL BE USED BY OR DISCLOSED TO ANY PERSON, FIRM OR CORPORATION FOR ANY PURPOSE WHATSOEVER WITHOUT THE WRITTEN PERMISSION OF HYPERPRO.

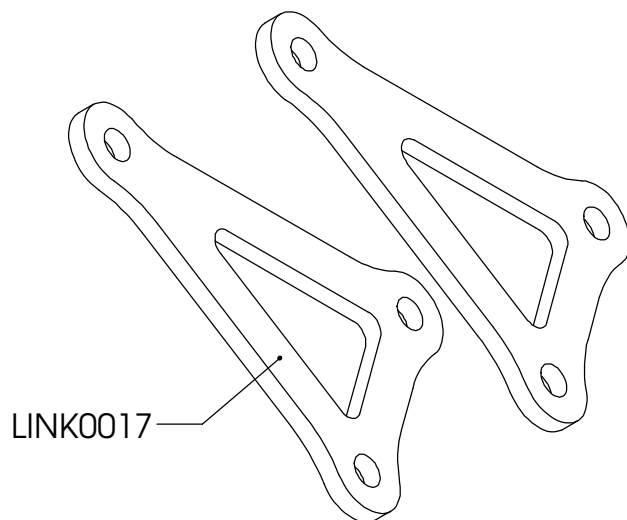

## Inbouw handleiding

### VOORZIJD

De vorkpoten maximaal 15 mm door de bovenste kroonplaat heen steken. Aanslagringen onder de clip-ons verwijderen, zodat ze verplaatst kunnen worden. De veervoorspanning minimaal zetten (tegen de klok in draaien).

### ACHTERZIJD

De bestaande link vervangen door de HYPERPRO verlagingslink. Let er hierbij op dat de pijl BOVEN zit en in de rijrichting wijst. Het achterwiel eerst belasten voordat de link vastgezet wordt.

LET OP! DE LENGTE VAN DE ZIJSTANDAARD MOET 20mm INGEKORT WORDEN. AFTERMARKET SPATBORDEN KUNNEN NIET TOEGEPAST WORDEN.

## Instruction manual

### FRONT

Mount the fork legs max 15mm through the triple clamp. Remove the rings under the clip-ons so they can be moved. Turn the preload adjuster to minimum preload (counter clockwise).

### REAR

Replace the original link by the HYPERPRO lowering link. Make sure that the arrow is on TOP and points in the riding direction. Put some pressure on the rear wheel before tightening the link.

WARNING! SHORTEN THE SIDE-STAND 20mm. AFTERMARKET MUDGUARDS CAN NO LONGER BE USED.

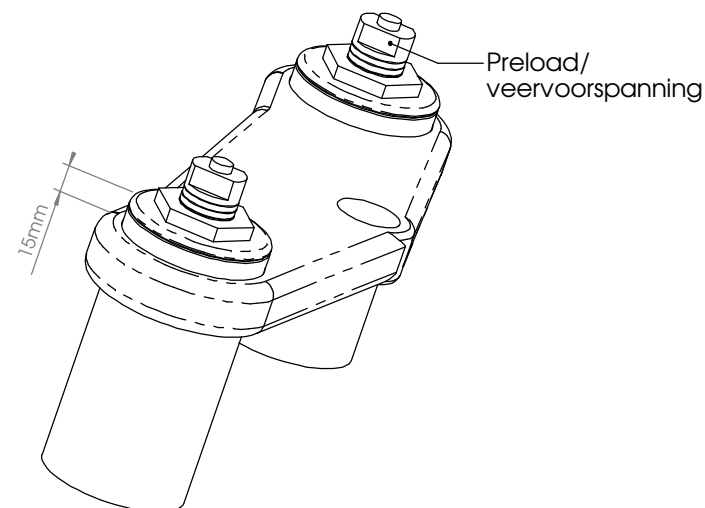

See [WWW.HYPERPRO.COM](http://WWW.HYPERPRO.COM) for more info about our products.